

An integer valued $SU(3)$ Casson invariant of homology 3-spheres

Christopher M. Herald
University of Nevada, Reno

(Casson 80's) defined $\lambda_{SU(2)}(X)$ for homology 3-spheres, $H_1(X; \mathbb{Z}) = 0$.

(Walker) extended it to $H_1(X; \mathbb{Q})$.

(Lescop) extended it to all 3-manifolds (combinatorially).

(Taubes) interpreted $\lambda_{SU(2)}$ in gauge theory.

(Floer) defined \mathbb{Z}_8 -graded instanton homology, with $\lambda_{SU(2)}$ as its Euler characteristic.

(Boden-H. 97) defined $\lambda_{SU(3)}$ for homology 3-spheres.

(BH) proved a connected sum theorem for $\lambda_{SU(3)}$.

(BH Kirk Klassen) calculated $\lambda_{SU(3)}$ for $1/k$ surgery on $(2, q)$ torus knots.

(BH Kirk) defined $\tau_{SU(3)} \in \mathbb{Z}$ for $\mathbb{Z}HS$'s, connected sum formula, $(2, q)$ torus knot calculations.

(H, in progress) generalized to $SU(n)$ for arbitrary n .

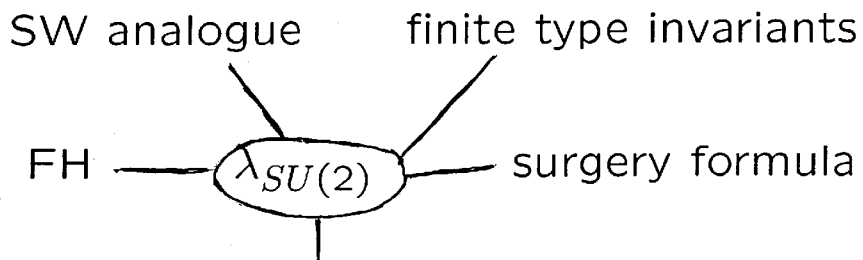

Witten, physics, $SU(n)$, finite type

(Casson)

$\lambda_{SU(2)}(X)$ = the number of representations $\rho : \pi_1 X \rightarrow SU(2)$ up to conjugation, counted with sign.

I'll focus on the gauge theory description. Keep in mind the Poincaré-Hopf theorem.

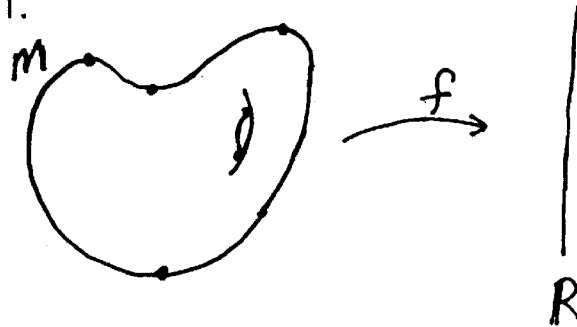

$$\sum_{p \in \text{crit}(f)} (-1)^{\mu(p)} = \chi(M).$$

$\mu(p)$ = Morse index = # neg. eigenvalues of the Hessian of f .

Morse index in the 2D case:

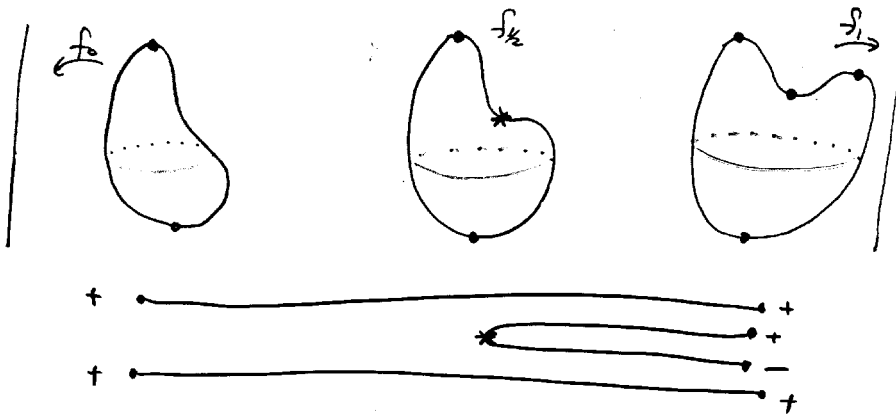
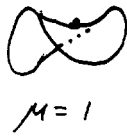
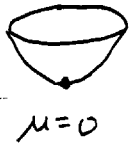

Note: $\#$ critical points, counted with sign, is independent of f . For a generic path of functions f , the critical sets form a cobordism.

Gauge theory

Let $X = \mathbb{Z}HS$ (i.e., $H_1(X; \mathbb{Z}) = 0$).

$\mathcal{A} = \{\text{connections on } X \times SU(n)\}$

$\mathcal{G} = \text{Aut}(X \times SU(n)) = \text{gauge group}$

$\mathcal{A}/\mathcal{G} = \infty\text{-dim. manifold w/ singularities}$

(reducible connections have nontrivial stabilizer. \Rightarrow quotient singularities)

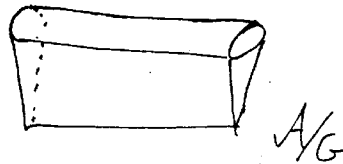
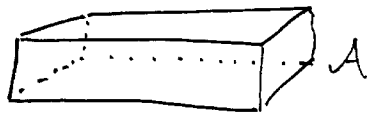

Morse theory on \mathcal{A}/\mathcal{G}

The Chern-Simons function $cs : \mathcal{A} \rightarrow \mathbb{R}$ satisfies $cs(gA) = cs(A) + \deg g$, where $\deg(g) \in \pi_0\mathcal{G} \cong \mathbb{Z}$

So $cs : \mathcal{A}/\mathcal{G} \rightarrow \mathbb{R}/\mathbb{Z}$.

Critical set of cs equals

$$\begin{aligned} \mathcal{M} &= \{\text{flat connections}\}/\mathcal{G} \\ &\cong \text{Hom}(\pi_1 X, SU(n))/\text{conjugation}. \end{aligned}$$

Idea: find “Euler characteristic” of \mathcal{A}/\mathcal{G} , an invariant of X .

(Taubes) For $SU(2)$, $X = \mathbb{Z}HS$, the critical set of cs stays away from singularities in \mathcal{A}/\mathcal{G} .

$$\sum_{[A] \in \text{crit}(cs+h)} (-1)^{SF(\theta, A)}$$

is independent of suitable perturbation h and equals $\lambda_{SU(2)}$.

The Hessian of cs has infinitely many \pm eigenvalues, but SF counts how many cross zero between the trivial connection θ and A .

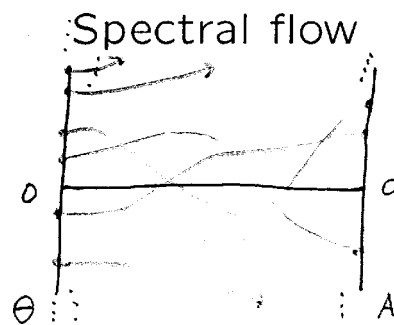

For $SU(n), n \geq 3$, the critical points DO interact with the singularities, so the sum is dependent of the perturbation h .

Simple model

Consider S^2 with S^1 acting on it with two fixed points, and $f : S^2 \rightarrow \mathbb{R}$ invariant. Critical set depends on f in a more complicated way.

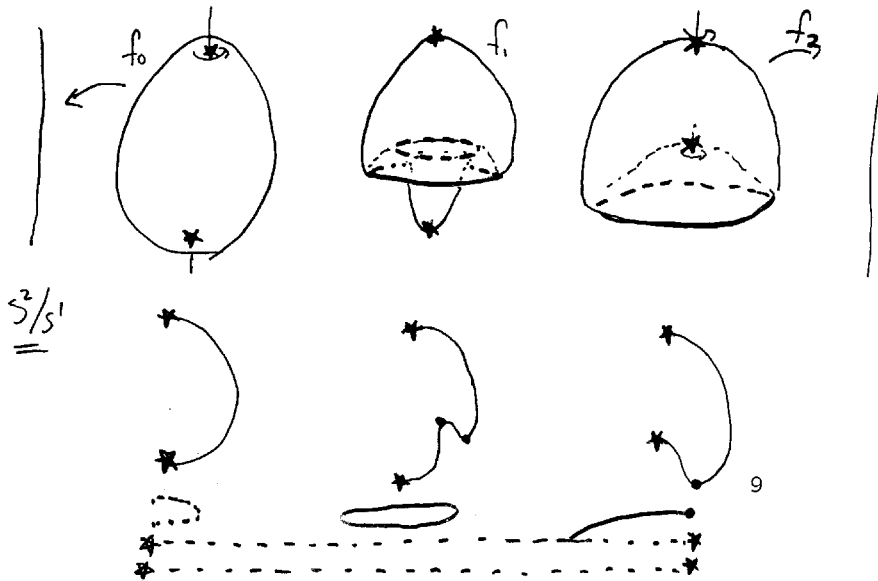

More generally:

Given M^n with semifree S^1 action, let $L = \{\text{fixed points}\} \subset M$. For a critical point $p \in L$,



$$\mu(p) = \mu_T(p) + \mu_N(p).$$

Theorem (BH) The quantity

$$\chi^{S^1}(M) = \sum_{\text{crit. } [C] \not\subset L} (-1)^{\mu(C)}$$

$$= \sum_{\text{crit. } p \in L} (-1)^{\mu(p)} \left(\frac{\mu_N(p)}{2} \right)$$

is independent of f . It equals $\chi(M/S^1, L/S^1)$

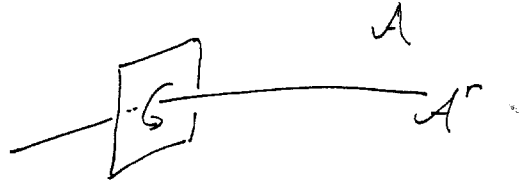

Similarly, along the set of reducible $SU(3)$ connections (with stabilizer $\cong U(1)$), we can decompose the Hessian of cs and spectral flow into tangential and normal components.

The correction term should look like

$$\sum_{[B] \in \mathcal{M}_h^r} (-1)^{SF(\theta, B)} \frac{SF_N(B_0, B)}{2}$$

for some reducible B_0 .

$$\mathcal{M}_h^r = \{\text{reducible crit. points of } cs+h\}/\mathcal{G}.$$

In [Boden, – '97], we used $B_0 = \theta$, but then $SF_N(\theta, B)$ depends on the gauge representative of $[B]$.

So we used (roughly)

$$\lambda''(X; h) = \sum_{[B] \in \mathcal{M}_h^r} (-1)^{SF(\theta, B)} \frac{(SF_N(\theta, B) - 4cs(B) + 2)}{2}$$

$$\lambda_{SU(3)}(X) = \sum_{[A] \in \mathcal{M}_h^*} (-1)^{SF(\theta, A)} + \lambda''(X; h).$$

Theorem [Boden, -]

$$\lambda_{SU(3)}(X) = \sum_{[A] \in \mathcal{M}_h^*} (-1)^{SF(\theta, A)} \lambda''(X; h)$$

is independent of generic small h .

Theorem [B, -]

$$\lambda_{SU(3)}(-X) = \lambda_{SU(3)}(X).$$

Theorem [B, -] $\lambda_{SU(3)} - 2\lambda_{SU(2)}^2$ is additive under connected sum.

Although $SF_N - 4cs$ form generalizes the Casson-Walker invariant, $\lambda_{SU(2)}$ has disadvantages:

1. Chern-Simons values are not even known to be rational.
2. Calculations [Boden, –, Kirk, Klassen] for surgeries on $(2, q)$ torus knots show $\lambda_{SU(3)}$ is not finite type of any order.

Improvement

\mathbb{Z} -valued correction term [B, –, Kirk]

\mathcal{G}_0 is the identity component of \mathcal{G} .

$$\mathcal{G}/\mathcal{G}_0 \cong \mathbb{Z}.$$

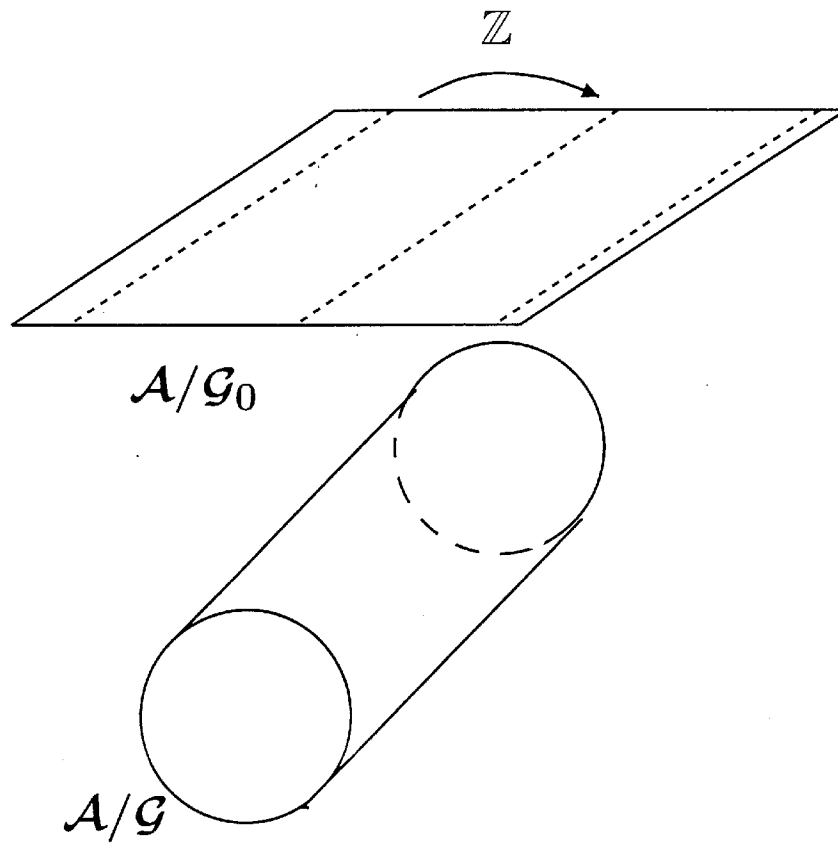

1. $cs(gA) = cs(A) + \deg(g)$.
2. cs is constant on components of $\tilde{\mathcal{M}} \subset \mathcal{A}/\mathcal{G}_0$.

Thus $\tilde{\mathcal{M}} \rightarrow \mathcal{M}$ is a *trivial* \mathbb{Z} -cover.

Choose disjoint neighborhoods of the components small enough that they also have a trivial \mathbb{Z} -cover. Choose representatives for gauge orbits and spectral flow paths within these neighborhoods.

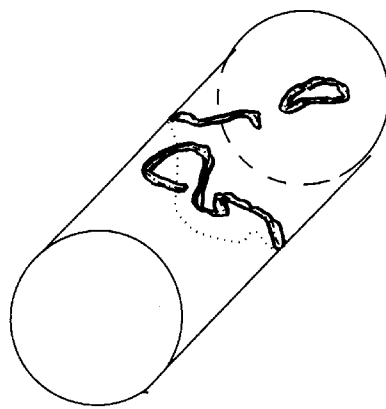
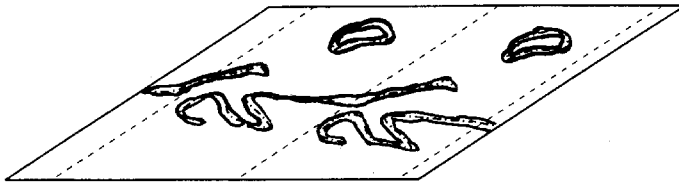

• perturbed
critical
point
- - - unperturbed
crit. set

Number components $C_1, \dots, C_n \subset \mathcal{M}^r$.

Define $\tau''(X; h)$ to be

$$\begin{aligned} & \frac{1}{4} \sum_{i=1}^n \sum_{\substack{[B] \in \mathcal{M}_h^r \\ \text{near } C_i}} (-1)^{SF(\theta, B)} \left(SF_N(B_i^+, B) \right. \\ & \qquad \qquad \qquad \left. + SF_N(B_i^-, B) \right) \\ & = \frac{1}{4} \sum_{i=1}^n \sum (-1)^{SF(\theta, B)} \left(2SF_N(B_i^+, B) \right. \\ & \qquad \qquad \qquad \left. - SF_N(B_i^-, B_i^+) \right). \end{aligned}$$

The first N spectral flow is even because the $Stab(B) \cong U(1)$ action on the normal bundle commutes with the Hessian of cs .

In the other term, B_i^\pm are $SU(2) \times \{1\}$ connections acting on \mathbb{C}^2 .

[Timeout.]

[A miracle occurs.]

$SU(2) \subset \mathbb{H}$ acts on $\mathbb{C}^2 \cong \mathbb{H}$ by left quaternionic multiplication. This commutes with right quaternionic multiplication.

So the eigenspaces of the signature operators for a path of $SU(2) \times \{1\}$ connections between B_i^- and B_i^+ are quaternionic and have dimension 4.

Therefore τ'' is an integer.

Timeout

Reducible representations take values
in $S(U(2) \times U(1)) = \left\{ \begin{bmatrix} * & * & 0 \\ * & * & 0 \\ 0 & 0 & * \end{bmatrix} \right\}$.

The normal bundle to this subgroup
has fiber $\left\{ \begin{bmatrix} 0 & 0 & z \\ 0 & 0 & w \\ -\bar{z} & -\bar{w} & 0 \end{bmatrix} \right\} \cong \mathbb{C}^2$.

$SU(2) \times \{1\} \subset S(U(2) \times U(1)) \subset SU(3)$
acts on this \mathbb{C}^2 by the standard action.

Theorem [B, -, K]

$$\tau(X) = \sum_{[A] \in \mathcal{M}_h^*} (-1)^{SF(\theta, A)} + \tau''(X; h)$$

is independent of h .

(i) $\tau(-X) = \tau(X)$.

(ii) $\tau - 2\lambda_{SU(2)}^2$ is additive under $\#$.

Claim (ii) is equivalent to

$$\begin{aligned} \tau(X_1 \# X_2) &= \\ \tau(X_1) + \tau(X_2) + 4\lambda_{SU(2)}(X_1)\lambda_{SU(2)}(X_2), \end{aligned}$$

a property already proven for $\lambda_{SU(3)}$. Thus we can prove it for τ by showing that the *difference between the correction terms* is additive on connected sums.

Proposition

For any $\alpha_1, \dots, \alpha_n \in \mathbb{R}$, the sum

$$\sum_{i=1}^n \sum_{\substack{[B] \in \mathcal{M}_h^r \\ \text{near } C_i}} (-1)^{SF(\theta, B)} \alpha_i$$

is independent the choice of small generic perturbation h .

Each Bott-Morse component C_i contributes $\pm \chi(C_i) \alpha_i$.

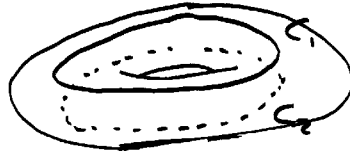

Corollary

If $\alpha^{X_1 \# X_2}$'s satisfy $\alpha^{X_1 \# X_2}(B \# \theta) = \alpha^{X_1}(B)$ and likewise for $(\theta \# B')$, then the resulting "invariant" is additive with respect to $X_1, X_2, X_1 \# X_2$.

Claim:

$$\lambda'' - \tau'' = \sum_{i=1}^n \sum_{\substack{[B] \in \mathcal{M}_h^r \\ \text{near } C_i}} (-1)^{SF(\theta, B)} \alpha_i$$

where

$$\alpha_i = \max_{[B] \in C_i} \left\{ \rho(B) + \frac{1}{2} \dim H_B^1(X; \mathbb{C}^2) \right\} \\ + \min_{[A] \in C_i} \left\{ \rho(B) - \frac{1}{2} \dim H_B^1(X; \mathbb{C}^2) \right\}.$$

These ρ invariants are for the fundamental representation of $SU(2) \times \{1\} \subset SU(3)$ on $(s(u(2) \times u(1)))^\perp \cong \mathbb{C}^2$.

$\rho(B) = SF_{\mathfrak{h}^\perp}(\theta, B) - 4cs(A) + 2 - \dim H_B^1(X; \mathfrak{h})$ is gauge invariant. (see [Kirk, Klassen, Ruberman])

20

Biggest selling point:

If some X doesn't really need a correction term, i.e., $H_B^1(X; \mathbb{C}^2) = 0$ along \mathcal{M}^r so that the count of irreducibles is independent of small perturbation, then $\tau''(X; h) = 0!!$

Some calculations for Brieskorn spheres:

X	$\tau(X)$
$\Sigma(2, 3, 6k \pm 1)$	$3k^2 \pm k$
$\Sigma(2, 5, 10k \pm 1)$	$33k^2 \pm 9k$
$\Sigma(2, 5, 10k \pm 3)$	$33k^2 \pm 19k + 2$
$\Sigma(2, 7, 14k \pm 1)$	$138k^2 \pm 26k$
$\Sigma(2, 7, 14k \pm 3)$	$138k^2 \pm 62k + 4$
$\Sigma(2, 7, 14k \pm 5)$	$138k^2 \pm 102k + 16$
$\Sigma(2, 9, 18k \pm 1)$	$390k^2 \pm 58k$
$\Sigma(2, 9, 18k \pm 5)$	$390k^2 \pm 210k + 24$
$\Sigma(2, 9, 18k \pm 7)$	$390k^2 \pm 298k + 52$

Calculations underway: surgeries on (p, q) torus knots $(\Sigma(p, q, r)$'s).

All of these except $(2, q)$ require perturbations. The moduli space contains "pointed 2-spheres" which contribute to the correction term. We now know how all of these contribute.

\mathcal{M} consists of:

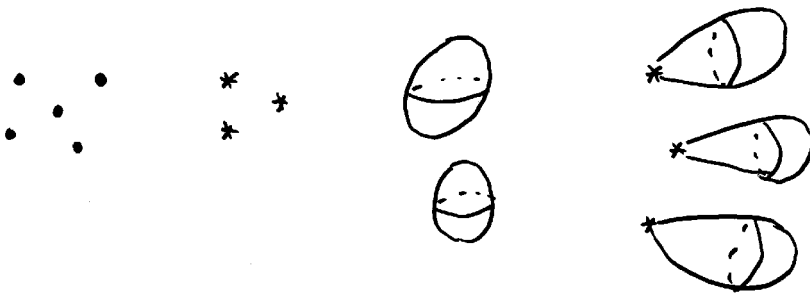

We just need to count up the objects in each class, and we'll have a table of τ values for $\Sigma(p, q, r)$.

Conjectures

1. On $\frac{1}{k}$ surgery on a knot, τ is quadratic in k . (Checked on $(3,4)$ torus knot. General surgeries on (p,q) torus knots and other $\Sigma(p,q,r)$ in progress.)
2. The quadratic coefficient agrees with the Frohman knot invariant.

Questions

3. Is it finite type? (It's known not to be of order 6.)
4. What is that mysterious linear coefficient?

Work in progress

For $SU(n)$, $n > 3$, there are more kinds of reductions (i.e., more orbit types). What types of bifurcations take place in the flat moduli space when one perturbs?

Relevant model

$M = SU(n)^N$ with $SU(n)$ action

$$g(g_1, \dots, g_N) = (g^{-1}g_1g, \dots, g^{-1}g_Ng).$$

(Wasserman '63 showed in general that there exist invariant Bott-Morse functions with isolated critical orbits.) What happens to the critical set of invariant functions $f_t : M \rightarrow \mathbb{R}$, $t \in [0, 1]$ for generic paths of functions?

\mathbb{Z}_3 invariant functions on \mathbb{R}^2

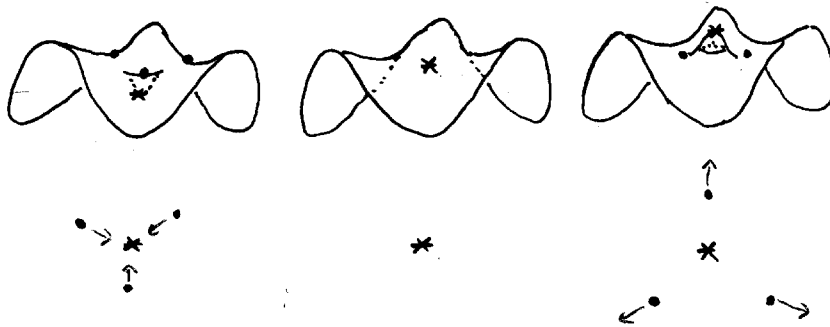

$S_2 \times \{\pm 1\}^2$ invariant functions on \mathbb{R}^2

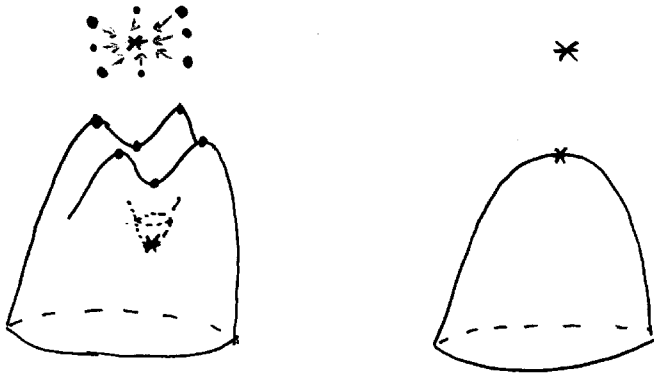

General story is “a linear combination”
of bifurcations analogous to these.